

Owner's Handbook:

Ride™ JAVA® Back Support



Ride Designs®

a branch of Aspen Seating, LLC

4211-G South Natches Court
Sheridan, Colorado 80110 USA

toll-free (U.S. Only): 866.781.1633
phone: 303.781.1633
www.ridedesigns.com

Supplier: This manual must be transferred to the end user of this product as it contains important information for proper use of this product.

User: Carefully read this entire manual prior to using this product and keep for future reference.

Intended Use and Installation Instructions

Intended Use

Your Ride Designs® Java® Back Support is an Adjustable Wheelchair Back Support that has been carefully constructed to meet your posture and skin integrity needs and has been designed to be mounted to multiple wheelchair styles and sizes to aid in supporting and positioning of wheelchair users.

Weight Capacity

Maximum user weight is 300 pounds (136kg).

Mounting Hardware

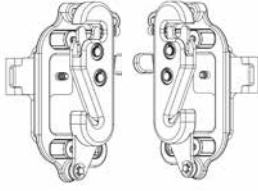

Back Shell Assembly

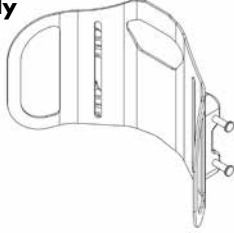

Cover Assembly



A. Outer Cover

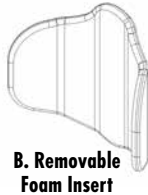

B. Removable Foam Insert

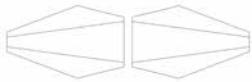

C. Pelvic Wedges



D. Flexa-just Accessories

Shell Depth Options

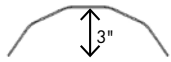

Regular

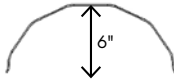

Deep

Shell Height Options



Regular



Tall

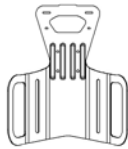

Grande

General Product Safety

Safe application of this product depends upon your good judgment and common sense, as well as that of your provider, caregiver, and/or healthcare professional, and your attentiveness in following the cautions, notes, and instructions in this manual.

NOTE: We have compiled this manual from the latest specifications and product information available at the time of publication. We reserve the right to make changes as they become necessary. Any changes to our products might cause slight variations between the illustrations and explanations in this manual and the product you have purchased. Always contact your nearest authorized Ride Designs supplier or distributor for the latest literature and information.

⚠ WARNING: Failure to heed these instructions could result in damage to the product or injury to the user.

⚠ All Ride Designs support surfaces are designed to help reduce the incidence of pressure sores. However, no back support can completely eliminate sitting pressure or prevent pressure sores. The Ride Java back support is not a substitute for good skin care including proper diet, cleanliness, and regular pressure relief techniques.

⚠ Installation of any back rest on your wheelchair might alter your center of gravity within the wheelchair. A recessed back position might cause the wheelchair to tip backwards, potentially resulting in injury. Always assess the need for anti-tippers or amputee axle adapter brackets to be added to your wheelchair to help increase stability. Similarly, a more forward back position might reduce the forward stability of the wheelchair, increasing risk of tipping forward, with potential for injury.

⚠ Do not use your Java Back without the foam insert and cover in place.

⚠ Failure to properly place and secure the Java Back to your wheelchair might result in injury.

⚠ Do not lift the wheelchair by the Java Back.

⚠ This product should be installed and fitted by a qualified and competent healthcare professional. Failure to accurately assess and adjust the fit of the Java Back Support could result in injury to the user.

⚠ Only Grande size back rests are designed with increased strength hardware for use in "Tilt in space" or other reclining style wheelchairs.

⚠ Please read this instruction manual before using this product.

Available Sizes

The Java Back is available in a range of sizes. Please visit www.ridedesigns.com for the most current information on size availability.

Installation Instructions

We recommend that a therapist or authorized Ride Designs supplier perform the initial fitting of your back support. Your Java Back is designed so that pelvic support and trunk balance can be adjusted independently of each other. Lateral pelvic wedges and the new Flexa-just™ support provides additional support and stability when needed.

The Java Back consists of three components: 1) Mounting hardware, 2) Back Shell Assembly, and 3) Cover assembly containing outer cover, removable foam insert, pelvic wedges, and Flexa-just accessories.

Tools and Hardware

The Java Back comes fully assembled and ready to install. The tools you need to install and adjust the Java Back are included in the package:

- one 4mm Allen wrench
- one 5mm Allen wrench
- two clamp screws for mounting back to ¾" (1.9cm) diameter back canes.

Mounting Hardware

The mounting hardware fits all common wheelchair frame tubing from ¾" to 1" (1.9cm to 2.54cm) diameter. Use the screws that are already in the clamps for 7/8" (2.2cm) and 1" (2.54cm) diameter tubing. Use the shorter screws, included in the Java Back Tools kit, for ¾" (1.9cm) tubing.

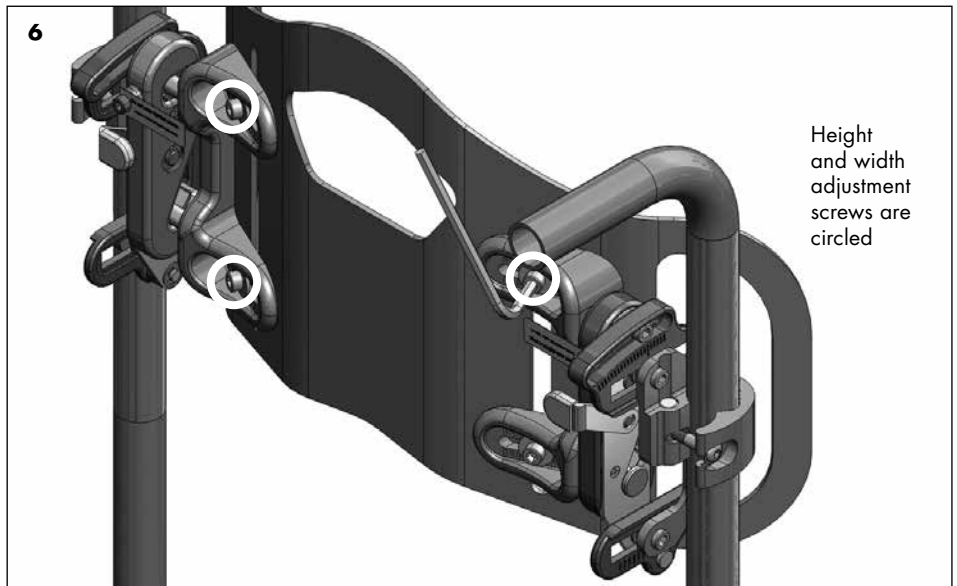
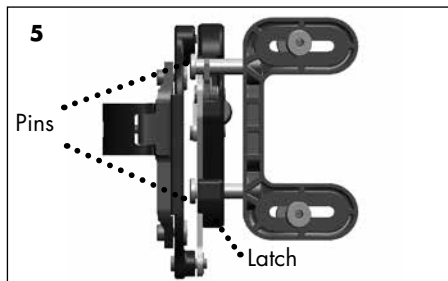
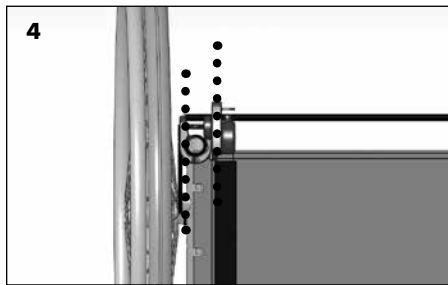
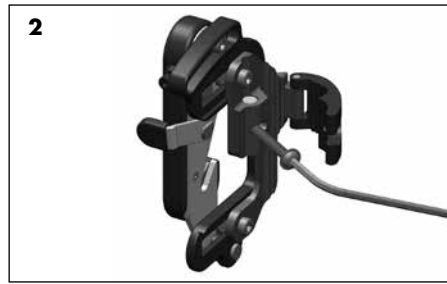
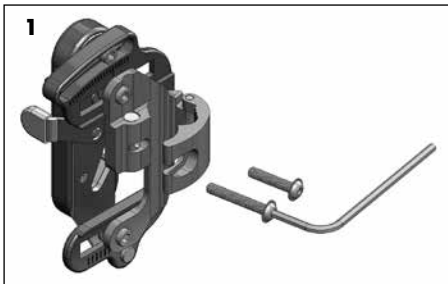

Installing the Mounting Hardware

⚠ No one should be seated in the wheelchair during the first four steps.

NOTE: Fastener torques not to exceed 75 in.- lbs. (8.5Nm) unless otherwise specified. If torque is specified for a piece of hardware, it is recommended that a torque meter (not included) should be used to ensure proper torque setting.

1. Loosen the clamp screw and swing it out of the recess in the clamp to allow the clamp to open fully (Illustration 2).
2. Position the clamp over the appropriate (left/right) wheelchair cane, pull the two halves of the clamp together around the tubing. Swing the screw back into position within the clamp recess (Illustration 3). Orient the clamp to approximate the desired back height. You will adjust for correct back height once the user is sitting in the wheelchair. Rotate the hardware about the canes so the hardware is square with the chair (Illustration 4).
3. Repeat steps 1 and 2 for the opposite clamp ensuring the clamp is set at the same height as the opposite side previously installed. Attach the back shell by guiding the bottom attachment pins into the lower receiver slots and then pushing the top attachment pins into the latch mechanism. Be sure both latch buttons pop back, and tug the back shell forward to verify that it is secure.
4. Wheelchair frame widths can vary from chair to chair. If you have any trouble aligning the mounting brackets with the attachment pins, you can easily adjust the width of the Java Back to fit perfectly.

⚠ Adjust hardware to ensure that pins fully engage through latch (Illustration 5).

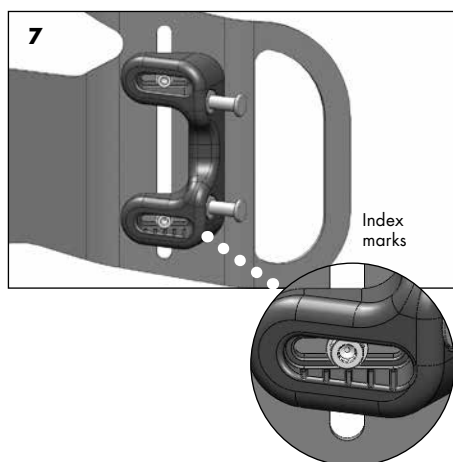

Use the 5mm Allen wrench to loosen the height and width adjustment screws indicated in Illustration 6. Move the pin brackets on the shell inward/outward enough to allow all four attachment pins to align and latch securely into the mounting hardware. Use the index marks provided (Illustration 7) to center the back shell on the pin brackets. Tighten the height and width adjustment screws securely.

NOTE: The Java Back is assembled at the factory to fit a wheelchair matching the width of the Java Back. The width adjustment screws allow for fine tuning of width as outlined above, and also have sufficient range of movement to permit installation of 15" (38cm) and wider Java Backs on wheelchairs +/- 1" (2.54cm) from specified width, e.g the 16" (41cm) wide Java Back can be adjusted to fit 15" (38cm), 16" (41cm) and 17" (43cm) wide wheelchairs.

5. Check to make sure the back shell detaches easily by pushing both latch release buttons (see Illustration 18) and pulling the back shell upward and forward. Make sure the back shell reattaches easily and securely by guiding the bottom attachment pins into the lower receiver slots and then pushing the top attachment pins into the latch mechanism. Be sure both latch buttons pop back, and tug the back shell forward to verify that it is secure. If there is any binding or if you have any trouble removing or replacing the back shell, repeat step 4 as necessary for smooth operation.

6. Place the appropriate wheelchair cushion on the wheelchair and have the user transfer to the wheelchair. Ensure the user is correctly positioned on the cushion.

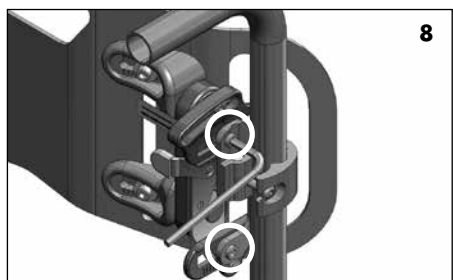

Adjusting the Seat Depth

If you need to adjust the seat depth, follow the instructions below.

1. Loosen the depth adjustment screws indicated (see Illustration 8).
2. Move the back shell to the appropriate seat depth for the user.
3. Tighten the screws just enough to hold the back in position, and use the index marks near the adjustment slots to be sure that both sides of the back are at the same depth.
4. When the depth is set correctly, torque all four depth adjustment screws to 60-70 in-lbs. (6.7~7.9 Nm).

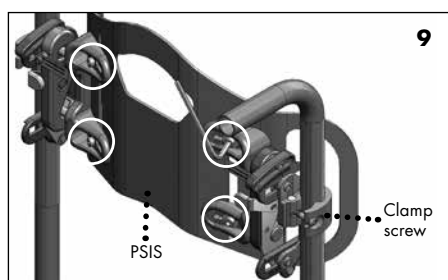

Adjusting the Back Height

1. Loosen the clamp screws and move the mounting brackets up or down on the back canes as necessary to set the back height so that the PSIS alignment line labeled near the bottom center of the Java back shell is at the level of the posterior superior iliac spines (PSIS). See Illustration 9.

2. Torque the two clamp screws to 75-85 in-lbs. (8.5~9.6 Nm).

3. If you need to position the mounting brackets to clear armrests, a rigidizer bar, or other wheelchair hardware, you can adjust the height of the back independently of the clamps. Begin by positioning the mounting clamps as close as possible to the desired back height. Then use the 5mm Allen wrench to loosen the height and width screws in the horizontal slots on the back shell brackets (Illustration 9), move the back shell to the desired height, and retighten the screws. Make sure the back shell is level from left to right, and that you have preserved the width adjustment for smooth and safe removal and replacement.

NOTE: Java Clamp Reversal Instructions

Clamps can be flipped upside down (Illustration 10) to achieve a higher backrest or to avoid interferences. See steps A-D.

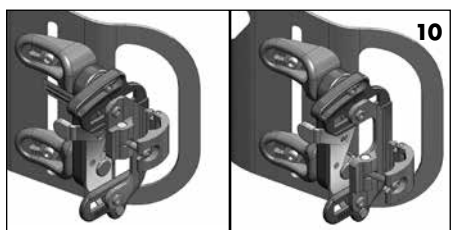

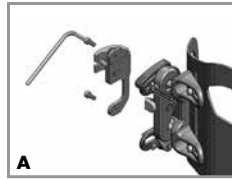

A
Remove the two clamp screws and two slot nuts from the mounting bracket and set aside.



B
Move clamp to opposite side of back.

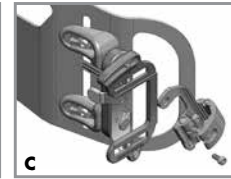

C
Flip clamp upside down.



D
Attach clamp to mounting bracket using the two clamp screws and two slot nuts from A.

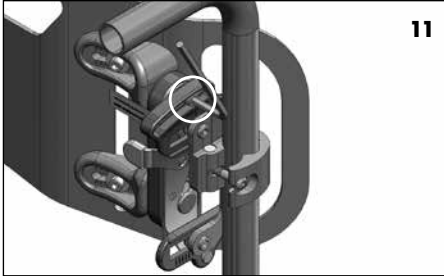

11

Adjusting Seat to Back Angle

1. Use the 5mm Allen wrench to loosen the back angle adjustment screws indicated in Illustration 11.
2. Adjust the Java Back to the desired seat-to-back angle.
3. Tighten the screws just enough to hold the back in position, and use the index marks near the adjustment slots to be sure that both sides of the back are at the same angle.
4. When the angle is set correctly, torque the screws to 75-85 in-lbs. (8.5~9.6 Nm).



12

Adjusting the Flexa-just Stays

1. The Flexa-just stays are thin aluminum strips inserted into pockets on the inside surface of the back cover, behind the foam pads. NOTE: The Flexa-just stays can be bent to provide comfortable support to the gluteal area below the level of the back shell. Depending on the unique needs of the user, you can easily adjust the stays to provide the correct amount of support.

The stays are easy to bend using hand pressure—no tools are required (Illustration 12).

2. The stays can be bent while the user is sitting in the wheelchair. Simply insert your hand between the foam insert and the sitter, grasp the lower portion of the stays through the cover and foam insert, and bend in the amount and direction needed to apply comfortable support.
3. If opening the back angle causes undesirable pressure or discomfort in the gluteal area, simply bend the Flexa-just stays posteriorly to accommodate and comfortably support the gluteal soft tissue.
4. If there is insufficient contact with the gluteal soft tissue, bend the stays anteriorly to provide optimum support.



13

Installing the Pelvic Wedges

NOTE: If you determine that further posterior lateral pelvic support is necessary, use the pelvic wedges to provide greater control at the posterior lateral iliac crests. See Illustration 13 for suggested orientation of pelvic wedges.

1. For evaluation, have the user lean forward enough for you to position the pelvic wedges on the front of the foam insert cover to establish where they should be installed.
2. Have the user lean back, and fine-tune the height and distance from the center for each pelvic wedge.
3. Have the user lean forward or transfer from the chair, and remove the foam insert and cover from the back shell.
4. Open the cover and attach the pelvic wedges to the front surface of the Flexa-just platform, behind the foam pad, at the height and width you determined during assessment. Press the hook and loop fasteners together firmly to hold the pelvic wedges in place.
5. Close the cover and reinstall the foam insert and cover on the chair.
6. The user can now transfer back into the wheelchair.
7. Check the position of the pelvic supports and verify that the user has appropriate balance and control.

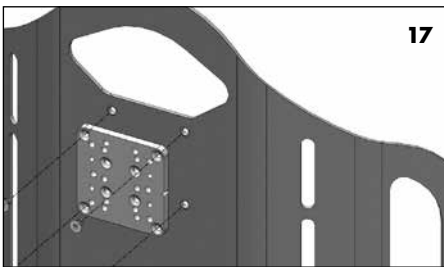
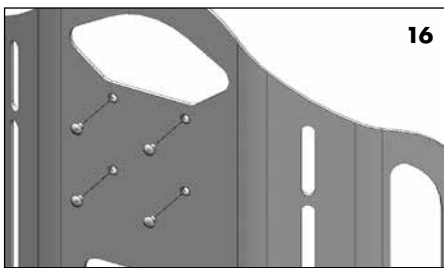
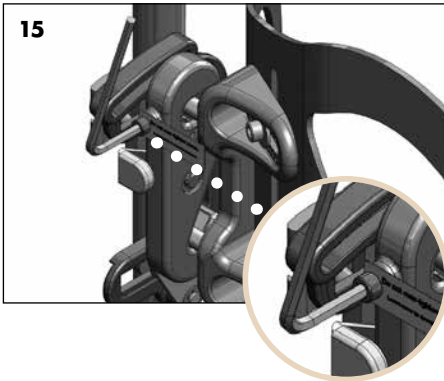
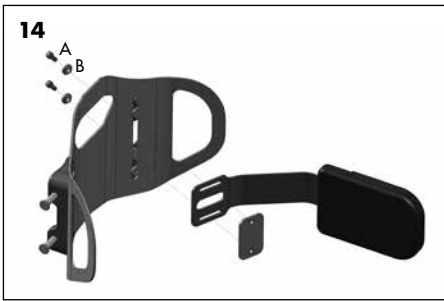

Installing the Optional Lateral Trunk Supports

NOTE: If you are not installing the optional lateral trunk supports, go to Adjusting Dynamic Back Movement section.

1. With the user in the chair and the foam insert and cover installed, estimate where the lateral trunk supports will be installed by slipping them between the back shell and the foam insert and cover (Illustration 14).
2. Once you have established the approximate position of the lateral trunk supports, transfer the user from the wheelchair.
3. Remove the foam insert and cover from the back shell.
4. Attach each lateral support using the mounting hardware and instructions supplied with them. With the lateral trunk support positioned on the front of the back shell, insert the provided screw (A) and non-threaded slot nut (B) from the outside of the back shell through the vertical slot in the back shell and the horizontal slot in the trunk support, and hand tighten into the nut plate (C).
5. Repeat for additional trunk supports.
6. Reattach the foam insert and cover.
7. The user can now return to the wheelchair for final adjustment of lateral trunk support alignment.
8. When you have determined the final position of the trunk supports, tighten the mounting hardware securely with a 5mm Allen wrench.

Adjusting Dynamic Back Movement

NOTE: As supplied by Ride Designs, the dynamic back adjustment is set to allow minimum movement. To increase dynamic back movement, follow the instructions below.

1. Use the 4mm Allen wrench to set the amount of travel for dynamic back movement (Illustration 15).
2. With the adjustment screws turned all the way in (clockwise), there is almost no dynamic back movement. Turning the adjustment screws out (counterclockwise) permits the back to move against spring tension.

NOTE: If you choose an intermediate amount of dynamic back movement, be sure that the screws on each side are adjusted equally by turning them all the way in and then backing them out the same number of turns.

Installing a Universal Headrest Mount

The tall and grande Java back shells have provisions for attaching a Universal Headrest Mount, which is available through your Ride Designs supplier. The Universal Headrest Mount accepts most commercially available headrests. To attach the Universal Headrest Mount, use the mounting hardware provided with the mount and attach to the four threaded inserts located on the upper portion of the back shells (Illustrations 16 and 17).

Ensure all Fasteners are secure

Using the 4mm and 5mm Allen wrenches, recheck all of the fasteners and tighten them securely.

Initial wearing schedule

Prior to prolonged sitting, you should use your Ride Java Back for a short period of time and visually check any area that contacts the back support. Any reddened area should fade within 10-30 minutes. Contact your doctor or therapist if redness persists for longer than 30 minutes. As long as skin inspections do not show red areas persisting more than 30 minutes, you are safe to continue use. Make a careful skin check at least daily, even after skin tolerance is established. Continue to perform routine intermittent pressure relief techniques (forward lean) as advised by your healthcare professional.

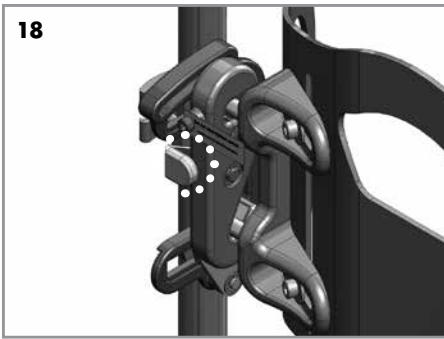

⚠ If any redness associated with the use of the Java Back persists for longer than 30 minutes, cease using and contact your therapist or doctor immediately.

Follow-up

We recommend you have your seated posture and skin integrity checked by your healthcare professional at least annually, or whenever you experience a change in your weight, posture, or general condition that could impact your ability to sit safely, comfortably, and functionally.

Retighten all of the fasteners regularly, and periodically check the hardware for security and wear.

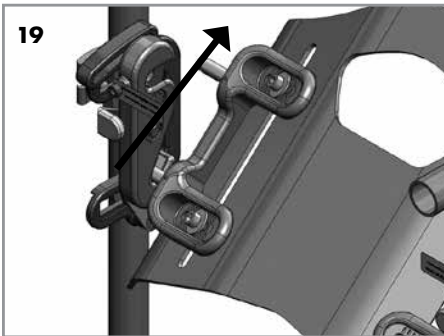

Use of your Ride Java Back

Your Ride Java Back is designed to provide optimal pelvic support and trunk balance while allowing upper body freedom.

You can remove or attach the back shell with one hand.

To remove the back shell from the wheelchair



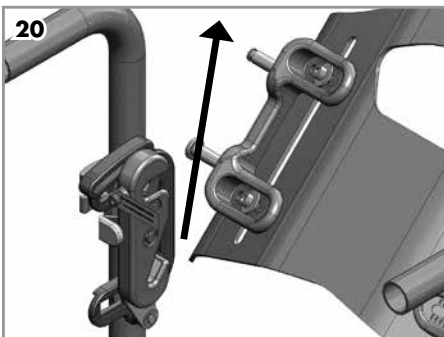

1. Push each of the two latch release buttons on the mounting hardware (Illustration 18).
2. Rotate the back shell forward then lift upward (Illustration 19 and 20).

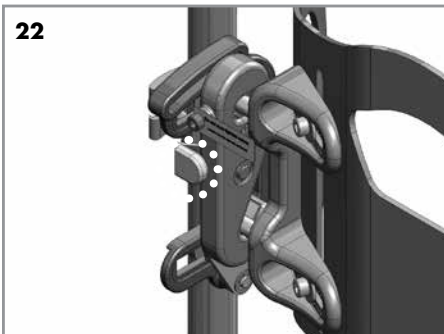
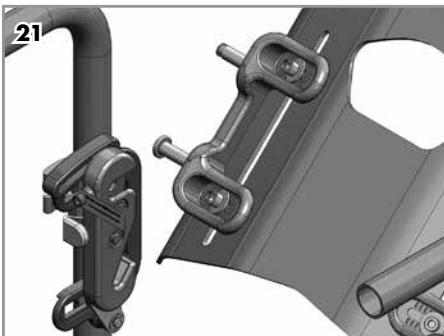

To attach the back shell to the wheelchair

1. Guide the bottom two attachment pins into the lower receiver slots on the latch brackets (Illustration 21).
2. Push the back shell down and back firmly to engage the top two attachment pins into the upper receiver slots (Illustration 22).
3. Check that both latch release buttons have popped back, indicating that the latches are engaged (Illustration 22).
4. Tug the back shell forward to verify that it is attached securely.



Laundry Care Symbols	
	Machine wash warm water (40° C)
	Do not bleach
	Drip dry
	Do not dry clean
	Do not iron

Care and Maintenance of your Ride Java Back

Cleaning the Java Back outer cover

1. Remove the foam insert and cover from the Java back shell.
2. Open the cover and remove the foam pad, Flexa-just stays (make note of left and right, and direction of bend), and flexa-just platform with pelvic wedges from the outer cover.
Note: Ride Designs recommends using a permanent marker to carefully outline the position of the pelvic wedges so that you can reattach them in the same positions if moved during cleaning.
3. Close the cover. Machine or hand wash the cover in warm water (40°C regular detergent, no bleach).
4. Hang dry.

Cleaning the Java Back shell and hardware

Using a damp cloth or mild disinfectant, clean the shell, pelvic wedges, and mounting hardware as needed.

NOTE: Do not clean your Java Back with isopropyl alcohol or any other chemical solvents.

Assembling the outer cover

1. Re-attach pelvic wedges to Flexa-just platform then roll up the foam pad and Flexa-just platform together to make installation into the cover easier (Illustration 23).
-  Installing the Flexa-just stays or new pelvic wedges in the wrong position could result in injury to the user.
2. Insert the foam pad and Flexa-just platform into the outer cover with flap folded back for maximum access to cover opening (Illustration 24).
 3. Spread out foam pad and Flexa-just platform inside the cover taking care to ensure they are inserted as far as possible into the interior perimeter edges of the cover (Illustration 25).
 4. Close the cover by pulling sufficiently on the cover flap to ensure full engagement of the hook and loop materials (Illustration 26).





Attaching Java cover assembly to back shell

1. Feed plastic clip through handle opening and attach to top of back shell (Illustrations 27 and 28).
2. Wrap cover over back shell pulling from the bottom of the cover. Take care that the cover is centered with the back shell (Illustration 29).
3. Push cover into back shell firmly to ensure joining of hook and loop fasteners on cover and back shell.

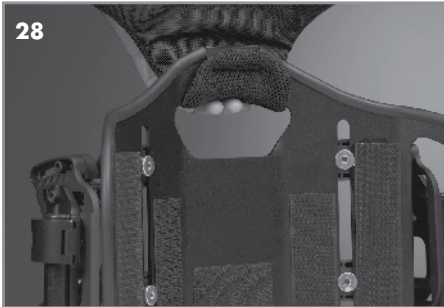

Attaching the Java Deep cover assembly to the back shell

Follow Installation instructions for regular Java shells but take care to ensure shell is inserted fully into outer cover side pockets. (Illustration 30).



Motor vehicle safety

⚠ RISK OF INJURY: The Java back has NOT been dynamically tested for use in a motor vehicle. Do not rely on a Java backrest for safe impact support in a motor vehicle. Serious injury or death could occur during a motor vehicle accident without proper Original Equipment Manufacturer vehicle safety features being utilized.

1. Always transfer out of your Java backrest and into Original Equipment Manufacturer vehicle seat and restraints for motor vehicle travel.



Maintenance

The Java Back and hardware should be routinely checked every 6 months minimum for loose, missing or damaged hardware and proper functionality. Inspect and tighten all hardware according to this manual. Contact your authorized Ride Designs supplier regarding any damaged or missing components.

⚠ Do NOT continue to use your product with any loose, missing or damaged components.

The maximum intended usage of this product is four years.

Reuse

⚠ RISK OF INJURY: Consult an authorized Ride Designs dealer before transferring to another user. Do NOT use product if any damage is found.

Disposal

♻ Recycle components and materials per local, state, and national regulations.

Warranty Policy

Your Ride Designs® Java® Adjustable Wheelchair Back Support has been carefully constructed to meet your posture and skin integrity needs. This Limited Warranty is effective for 24 months from the date of delivery to the original purchaser. If any defect in material or workmanship is found, Ride Designs will repair or replace the component, at our discretion. This limited warranty does not cover daily wear and tear or damage that is a result of mishandling, misuse, neglect, or not following the care and maintenance instructions.

Claims and repairs should be processed through your nearest authorized Ride Designs rehab technology supplier or distributor. A copy of the Bill of Sale issued to the purchaser of the product might be required prior to processing a warranty claim.



The Ride Java Back support works best when used with the Ride Java® Cushion, Ride Forward™ Cushion or Ride Custom Cushion (U.S. Only)

Achieve a high level of skin protection and functional performance with the Ride Java Cushion (only the Ride Custom Cushion can provide a higher level of protection and support). The Ride Forward Cushion is most appropriate for people with mild to moderate risk for skin breakdown.

Installation Notes

Patents: www.ridedesigns.com/patents
© 2015, Ride Designs. 090-105-B



MDSS GmbH
Schiffgraben 41
30175 Hannover, Germany