

# Ride JAVA™ Adjustable Back Support Owner's Handbook

---

## ► **Warranty Policy Installation and Use Instructions**

### **Warranty Policy**

Your Ride Designs® JAVA™ Adjustable Back Support has been carefully constructed to meet your posture and skin integrity needs. This Limited Warranty is effective for 24 months from the date of delivery to the original purchaser. If any defect in material or workmanship is found, Ride Designs will repair or replace the component, at our discretion. This limited warranty does not cover daily wear and tear or damage that is a result of mishandling, misuse, neglect, or not following the care and maintenance instructions.

Claims and repairs should be processed through your nearest authorized Ride Designs rehab technology supplier. A copy of the Bill of Sale issued to the purchaser of the product might be required prior to processing a warranty claim.

Maximum client weight capacity is 300 pounds.

---

► **Ride Designs®**  
a branch of Aspen Seating, LLC  
4211-G South Natches Court  
Sheridan, Colorado 80110

toll-free: 866.781.1633  
phone: 303.781.1633  
[www.ridedesigns.com](http://www.ridedesigns.com)

## General Product Safety

Safe application of this product depends upon your good judgment and common sense, as well as that of your provider, caregiver, and/or healthcare professional, and your attentiveness in following the warnings, cautions, notes, and instructions in this manual.

**NOTE:** Denotes important things to remember when using this product.

**WARNING:** Indicates a potentially dangerous situation that, if not heeded, could result in serious injury.

**CAUTION:** Failure to heed cautions might result in damage to your product.

**NOTE:** Ride Designs is not liable for damage to property or personal injury arising out of unsafe use of this product. Ride Designs is also not liable for any property damage or personal injury arising out of the failure of any person and/or user to follow the instructions or recommendations set forth in 1) this manual, or 2) any other instructions or recommendations contained in related literature issued by Ride Designs, or 3) contained on the product itself, or 4) on our website [www.ridedesigns.com](http://www.ridedesigns.com).

**NOTE:** We have compiled this manual from the latest specifications and product information available at the time of publication. We reserve the right to make changes as they become necessary. Any changes to our products might cause slight variations between the illustrations and explanations in this manual and the product you have purchased.

**WARNING:** All Ride Designs support surfaces are designed to help reduce the incidence of pressure sores. However, no back support can completely eliminate sitting pressure or prevent pressure sores. The Ride JAVA back support is not a substitute for good skin care including proper diet, cleanliness, and regular pressure relief techniques.

## Available Sizes

The JAVA back is available in a range of sizes. Please visit [www.ridedesigns.com](http://www.ridedesigns.com) for the most current information on size availability.

## Installation Instructions

We recommend that a therapist or authorized Ride Designs supplier perform the initial fitting of your back support. Your JAVA back is designed so that pelvic support and trunk balance can be adjusted independently of each other. Lateral pelvic wedges and the new Flexa-just™ support provides additional support and stability when needed.

The JAVA back consists of four components: 1) mounting hardware, 2) Flexa-just accessories, 3) the back shell, and 4) the removable foam insert and cover.

**WARNING:** Installation of any back rest on your wheelchair might alter your center of gravity within the wheelchair. A recessed back position might cause the wheelchair to tip backwards, potentially resulting in injury. Always assess

the need for anti-tippers or amputee axle adapter brackets to be added to your wheelchair to help increase stability. Similarly, a more forward back position might reduce the forward stability of the wheelchair, increasing risk of tipping forward, with potential for injury.

**WARNING:** Do not use your JAVA back without the foam insert and cover in place.

**WARNING:** Failure to properly place and secure the JAVA back to your wheelchair might result in serious injury.

**WARNING:** Failure to accurately assess and adjust the fit of the JAVA back might result in serious injury.

**CAUTION:** Do not lift the wheelchair by the JAVA back.

## I. Tools and Hardware

The JAVA back comes fully assembled and ready to install. The tools you need to install and adjust the JAVA back are included in the package:

- one 4mm Allen wrench
- one 5mm Allen wrench

A plastic bag with four screws also comes packed with the JAVA back. They are needed only when installing the JAVA back on wheelchairs with  $\frac{3}{4}$  inch diameter back canes.

## II. The Mounting Hardware

The mounting hardware fits all common wheelchair frame tubing from  $\frac{3}{4}$ " to 1" diameter. Use the screws that are already in the clamps for  $\frac{7}{8}$  inch and 1 inch diameter tubing. Use the shorter screws (in the plastic bag included in the package marked "For  $\frac{3}{4}$  inch back canes") for  $\frac{3}{4}$  inch tubing. On some installations, the lower clamp may be located on one size tubing and the upper clamp on smaller diameter tubing that telescopes inside the lower tubing. To use the clamps on telescoped tubing of two different sizes, tighten the set screw near the top of each clamp (Figure 1), then install the clamps as described below.

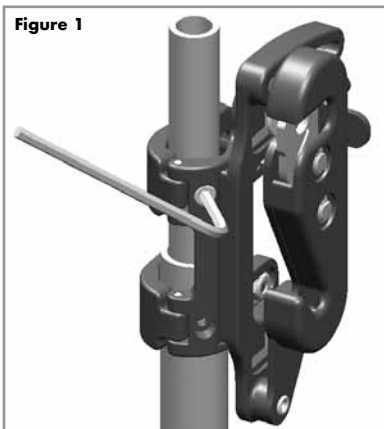

### III. Installing the Mounting Hardware

**WARNING:** No one should be seated in the wheelchair during the first four steps.

1. The Java back ships with the back shell engaged with the mounting hardware to assist in visualizing final assembly on to the wheelchair.

2. Press the release latch button (Figure 2) on one of the hardware assemblies to separate the mounting hardware from the back shell.

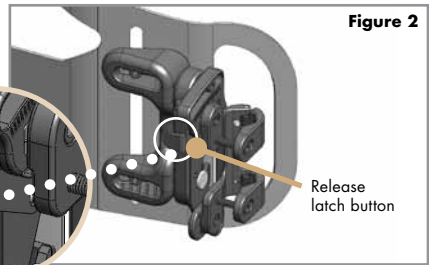

3. Remove the two clamp screws from the mounting brackets (Figure 3) to allow the clamps to open fully.

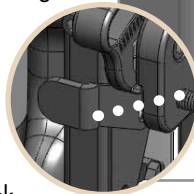

**NOTE:** If installing the Java back on wheelchairs without push handles, you can loosen the clamp screws and slide the clamp assembly down over the back cane.

4. Position the clamp over the appropriate (left/right) wheelchair cane, pull the two halves of the clamp together around the tubing and reinstall the screws (figure 4). Orient the clamp to approximate the desired back height. You will adjust for correct back height once the user is sitting in the wheelchair. Rotate the hardware about the canes so the hardware is square with the chair (Figure 5). Temporarily tighten the upper screw enough to hold the clamp in place.



5. Repeat steps 2 through 4 for the opposite clamp ensuring the clamp is set at the same height as the opposite side previously installed. Attach the back shell by guiding the bottom attachment pins into the lower receiver slots and then pushing the top attachment pins into the latch mechanism. Be sure both latch buttons pop back, and tug the back shell forward to verify that it is secure.

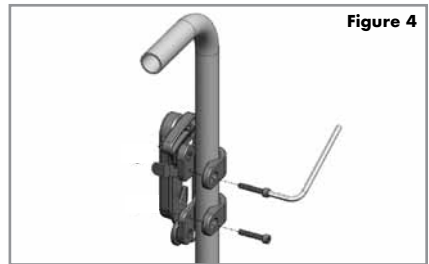

6. Wheelchair frame widths can vary from chair to chair. If you have any trouble aligning the mounting brackets with the attachment pins, you can

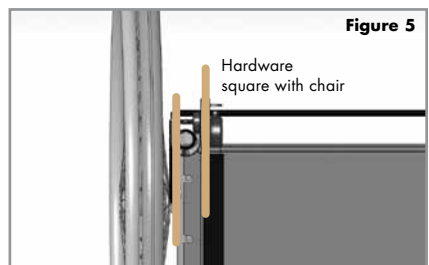



easily adjust the width of the JAVA back to fit perfectly. Use the 5mm Allen wrench to loosen the height and width adjustment screws indicated in Figure 6. Move the pin brackets on the shell inward/outward enough to allow all four attachment pins to align and latch securely into the mounting hardware. Use the index marks provided (Figure 7) to center the back shell on the pin brackets. Tighten the height and width adjustment screws securely.

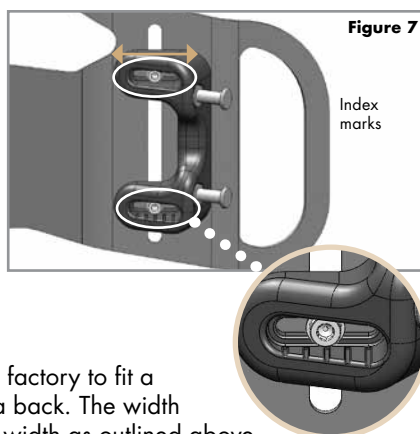

NOTE: The Java back is assembled at the factory to fit a wheelchair matching the width of the Java back. The width adjustment screws allow for fine tuning of width as outlined above, and also have sufficient range of movement to permit installation of 15" and wider Java backs on wheelchairs +/- 1" from specified width, e.g the 16" wide Java back can be adjusted to fit 15", 16" and 17" wide wheelchairs.

7. Check to make sure the back shell detaches easily by pushing both latch release buttons and pulling the back shell upward and forward. Make sure the back shell reattaches easily and securely by guiding the bottom attachment pins into the lower receiver slots and then pushing the top attachment pins into the latch mechanism. Be sure both latch buttons pop back, and tug the back shell forward to verify that it is secure. If there is any binding or if you have any trouble removing or replacing the back shell, repeat step 6 as necessary for smooth operation.

8. Place the appropriate wheelchair cushion on the wheelchair and have the user transfer to the wheelchair. Ensure the user is correctly positioned on the cushion.

## IV. Adjusting the Seat Depth

If you need to adjust the seat depth, follow the instructions below.

1. Loosen the depth adjustment screws indicated in Figure 8.
2. Move the back shell to the appropriate seat depth for the user.
3. Tighten the screws just enough to hold the back in position, and use the index marks near the adjustment slots to be sure that both sides of the back are at the same depth.
5. When the depth is set correctly, tighten all four depth adjustment screws securely.

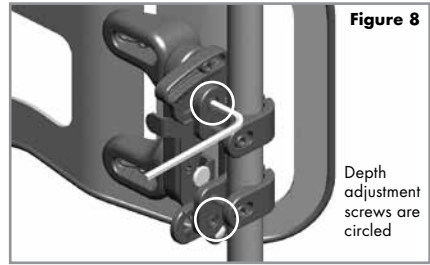

## V. Adjusting the Back Height

1. Loosen the clamp screws and move the mounting brackets up or down on the back canes as necessary to set the back height so that the PSIS alignment line labeled near the bottom center of the JAVA back shell is at the level of the posterior superior iliac spines (PSIS).
2. Tighten the four clamp screws securely.

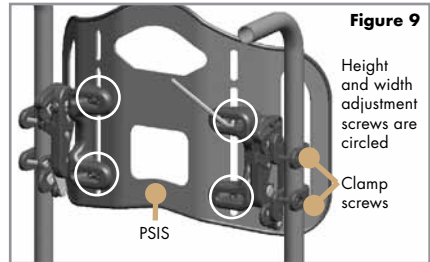

3. If you need to position the mounting brackets to clear armrests, a rigidizer bar, or other wheelchair hardware, you can adjust the height of the back independently of the clamps. Begin by positioning the mounting clamps as close as possible to the desired back height. Then use the 5mm Allen wrench to loosen the height and width screws in the horizontal slots on the back shell brackets (Figure 9), move the back shell to the desired height, and retighten the screws. Make sure the back shell is level from left to right, and that you have preserved the width adjustment for smooth and safe removal and replacement.

**NOTE:** As supplied by Ride Designs, the screws are positioned in the vertical adjustment slots so that the bottom of the back shell does not move forward or backward relative to the PSIS during back angle adjustments or dynamic back movement. Performing the adjustments described in Step 3 will cause the bottom of the shell to move forward and backward slightly relative to the PSIS during subsequent adjustments and use. The amount of movement will be proportional to the distance the back shell is moved in Step 3.

## VI. Adjusting the Seat to Back Angle

1. Use the 5mm Allen wrench to loosen the back angle adjustment screws indicated in Figure 10.

2. Adjust the JAVA back to the desired seat-to-back angle.

3. Tighten the screws just enough to hold the back in position, and use the index marks near the adjustment slots to be sure that both sides of the back are at the same angle.

4. When the angle is set correctly, tighten the screws securely.

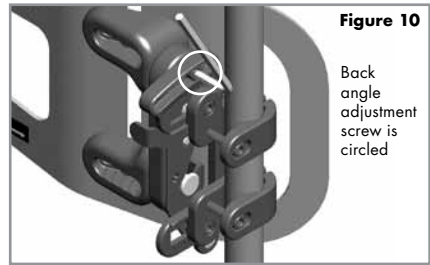

## VII. Adjusting the Flexa-just Stays

1. The Flexa-just stays are thin aluminum strips inserted into pockets on the inside surface of the back cover, behind the foam pads. NOTE: The Flexa-just stays can be bent to provide comfortable support to the gluteal area below the level of the back shell. Depending on the unique needs of the user, you can easily adjust the stays to provide the correct amount of support. The stays are easy to bend using hand pressure—no tools are required (Figure 11).

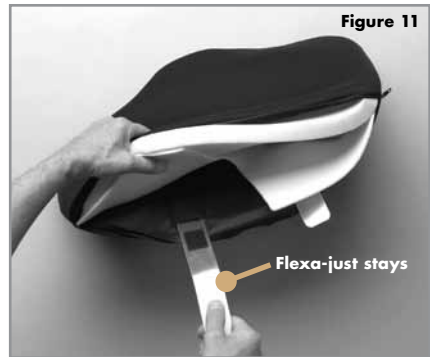

2. The stays can be bent while the user is sitting in the wheelchair. Simply insert your hand between the foam insert and the sitter, grasp the lower portion of the stays through the cover and foam insert, and bend in the amount and direction needed to apply comfortable support.

3. If opening the back angle causes undesirable pressure or discomfort in the gluteal area, simply bend the Flexa-just stays posteriorly to accommodate and comfortably support the gluteal soft tissue.

4. If there is insufficient contact with the gluteal soft tissue, bend the stays anteriorly to provide optimum support.

## VIII. Installing the Pelvic Wedges

NOTE: If you determine that further posterior lateral pelvic support is necessary, use the pelvic wedges to provide greater control at the posterior lateral iliac crests. See Figure 12 for suggested orientation of pelvic wedges.

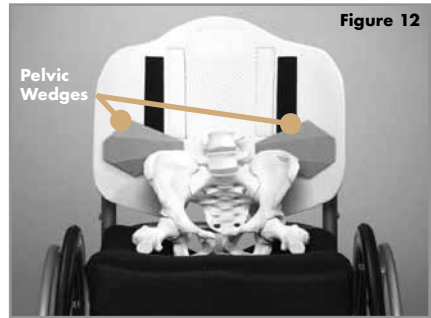

Figure 12

1. For evaluation, have the user lean forward enough for you to position the pelvic wedges on the front of the foam insert cover to establish where they should be installed.
2. Have the user lean back, and fine-tune the height and distance from the center for each pelvic wedge.
3. Have the user lean forward or transfer from the chair, and remove the foam insert and cover from the back shell.
4. Open the cover and attach the pelvic wedges to the front surface of the Flexa-just platform, behind the foam pad, at the height and width you determined during assessment. Press the hook and loop fasteners together firmly to hold the pelvic wedges in place.
5. Close the cover and reinstall the foam insert and cover on the chair.
6. The user can now transfer back into the wheelchair.
7. Check the position of the pelvic supports and verify that the user has appropriate balance and control.

## IX. Installing the Optional Lateral Trunk Supports

NOTE: If you are not installing the optional lateral trunk supports, go to Section X.

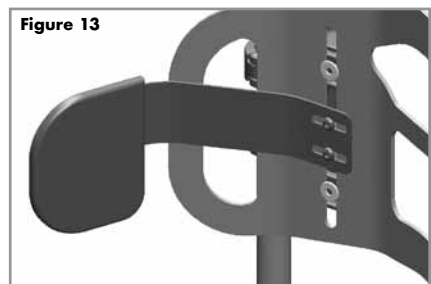

Figure 13

1. With the user in the chair and the foam insert and cover installed, estimate where the lateral trunk supports will be installed by slipping them between the back shell and the foam insert and cover (Figure 13).
2. Once you have established the approximate position of the lateral trunk supports, transfer the user from the wheelchair.
3. Remove the foam insert and cover from the back shell.
4. Attach each lateral support using the mounting hardware supplied with them. With the lateral trunk support positioned on the front face of the back shell, insert

provided screw from the inside of the back shell through the horizontal slot in the trunk support and the vertical slot in the back shell and into a threaded insert.

5. Repeat for additional trunk supports.
6. Reattach the foam insert and cover.
7. Position the user in the wheelchair and fine-tune the position of the trunk supports.
8. When you have determined the final position of the trunk supports, have the user lean forward (if it can be done safely) or transfer the user from the wheelchair. Remove the foam insert and cover, and tighten the mounting hardware securely.
9. Reinstall the foam insert and cover.
10. The user can now transfer back into the wheelchair.

## X. Adjusting Dynamic Back Movement

NOTE: As supplied by Ride Designs, the dynamic back adjustment is set to allow maximum movement. To reduce or eliminate dynamic back movement, follow the instructions below.

1. Use the 4mm Allen wrench to set the amount of travel for dynamic back movement (Figure 14).
2. With the adjustment screws turned all the way in (clockwise), there is no dynamic back movement. Turning the adjustment screws out (counterclockwise) permits the back to move against spring tension.

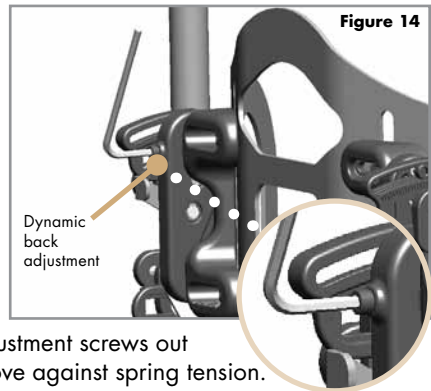

CAUTION: If you choose an intermediate amount of dynamic back movement, be sure that the screws on each side are adjusted equally by turning them all the way in and then backing them out the same number of turns.

## XI. Installing a Universal Headrest Mount

The tall JAVA back shell has provisions for attaching a Universal Headrest Mount, which is available through your Ride Designs supplier. The Universal Headrest Mount accepts most commercially available headrests. To attach the Universal Headrest Mount, remove the four small plastic plugs from the threaded inserts near the top of the back shell and use the mounting hardware provided (Figures 15 and 16).

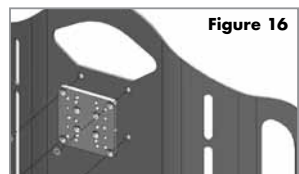
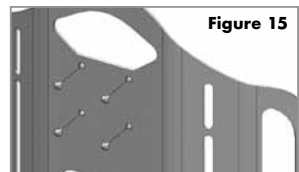

## XII. Ensure all Fasteners are secure

Using the 4mm and 5mm Allen wrenches, recheck all of the fasteners and tighten them securely.

## Initial wearing schedule

Prior to prolonged sitting, you should use your Ride JAVA back for a short period of time and visually check any area that contacts the back support. Any reddened area should fade within 10-30 minutes. Contact your doctor or therapist if redness persists for longer than 30 minutes. As long as skin inspections do not show red areas persisting more than 30 minutes, you are safe to continue use. Make a careful skin check at least daily, even after skin tolerance is established. Continue to perform routine intermittent pressure relief techniques (forward lean) as advised by your healthcare professional.

**WARNING:** If any redness associated with the use of the JAVA back persists for longer than 30 minutes, cease using and contact your therapist or doctor immediately.

## Follow-up

We recommend you have your seated posture and skin integrity checked by your healthcare professional at least annually, or whenever you experience a change in your weight, posture, or general condition that could impact your ability to sit safely, comfortably, and functionally.

Retighten all of the fasteners regularly, and periodically check the hardware for security and wear.

## Use of your Ride JAVA Back

Your Ride JAVA back is designed to provide optimal pelvic support and trunk balance while allowing upper body freedom.

You can remove or attach the back shell with one hand.

### To remove the back shell from the wheelchair

1. Push each of the two latch release buttons on the mounting hardware (Figure 17).
2. Rotate the back shell forward then lift upward (Figure 18 and 19).

### To attach the back shell to the wheelchair

1. Guide the bottom two attachment pins into the lower receiver slots on the latch brackets (Figure 20).

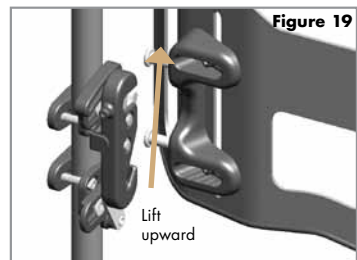
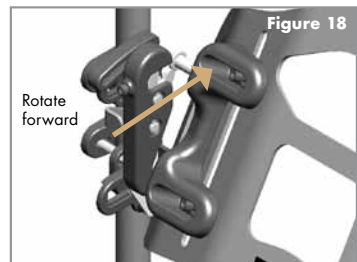
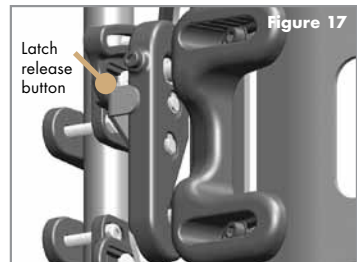

2. Push the back shell down and back firmly to engage the top two attachment pins into the upper receiver slots (Figure 21).

3. Check that both latch release buttons have popped back, indicating that the latches are engaged (Figure 21).

4. Tug the back shell forward to verify that it is attached securely.

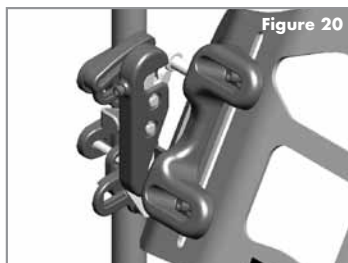

Figure 20

## Care and Maintenance of your Ride JAVA Back

### Cleaning the JAVA back foam insert and cover

1. Remove the foam insert and cover from the JAVA back shell.

2. Open the cover and remove the foam pad, Flexa-just stays (make note of left and right, and direction of bend), and flexa-just platform with pelvic wedges from the outer cover. Note: Ride Designs recommends using a permanent marker to carefully outline the position of the pelvic wedges so that you can reattach them in the same positions if moved during cleaning.

3. Close the cover. Machine or hand wash the cover in warm water (regular detergent, no bleach).

4. Hang dry.

5. When re-inserting the Flexa-just stays, return them to their correct pockets, facing in the correct direction.

6. Insert the foam pad and Flexa-just platform with pelvic wedges. Be sure the inserts are not folded or wrinkled inside the cover.

7. Close the cover and reattach the foam insert and cover to the back shell.

**WARNING:** Installing the Flexa-just stays or pelvic wedges in the wrong positions might result in serious injury to the user.

### Cleaning the JAVA back shell and hardware

Using a damp cloth or mild disinfectant, clean the shell, pelvic wedges, and mounting hardware as needed.

**CAUTION:** Do not clean your JAVA back with isopropyl alcohol or any other chemical solvents.

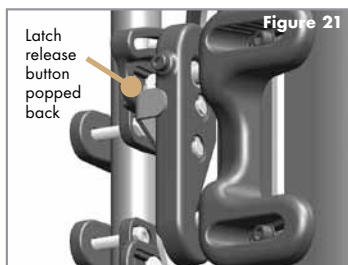

Figure 21

**The Ride JAVA Back support works best when used with the Ride Forward™ or Ride Custom Cushion.**

The Ride Forward cushion is most appropriate for people with mild to moderate risk for skin breakdown.

For people at higher risk for skin breakdown, and/or more challenging postural control needs, the **Ride Custom Cushion** is the ultimate in postural support and skin care. It is specifically contoured to support a person's unique size, shape, posture and functional requirements.



▲ The Ride Forward™ Cushion

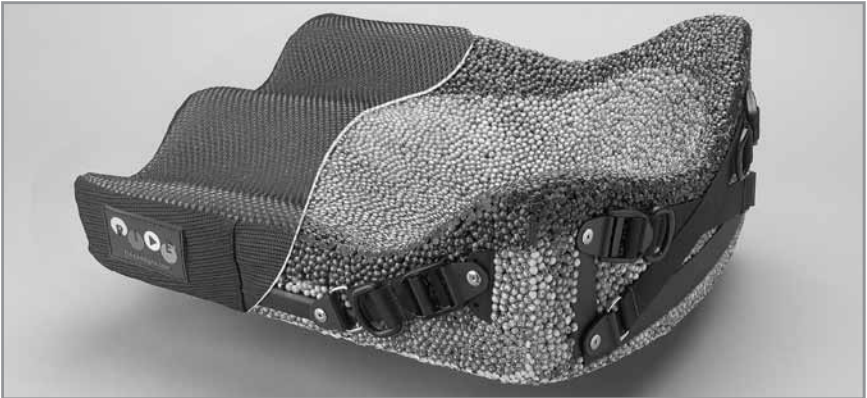

▲ The Ride Custom Cushion\*

\*Cut away view of spacer mesh integrated cushion cover.